

# Redco™ Chain Channels

## Lowest Coefficient of Friction

Due to big changes in our manufacturing processes, Redwood is proud to supply chain channels with the lowest coefficient of friction compared to our competitors. This means less wear on your chains, less noise and fewer maintenance and electrical costs. Redco™ Chain Channels are built to help metal chains glide through your operations

For more information about Redco™ Chain Channels, or to request a quote for your business, contact us.

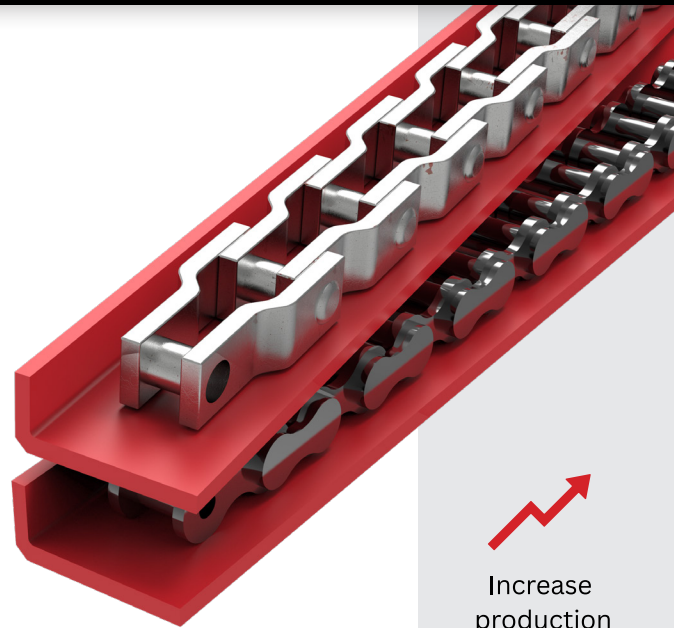

## Key Features

Lowest coefficient of friction compared to other chain channels

Reduces chain and belt wear and reduces noise

Saves premature replacement costs for your chain and equipment

Up to 16 different profiles, including for chains such as 81x, 81XH & H78

Available in many standard and custom profiles

Lowers electricity consumption and operating costs

Available in Titanium (longer wearing) and Synsteel (pulp-safe)



Increase production



Easy installation



Reduce energy consumption



Reduce noise



Corrosion & chemical resistance



sales@redwoodplastics.com  
Contact Us for a Quotation.

1.833.381.1195

# REDCO™ UHMW CHAIN CHANNEL PROFILES

Prolong Chain Life | Reduce Noise | Reduce Power Consumption

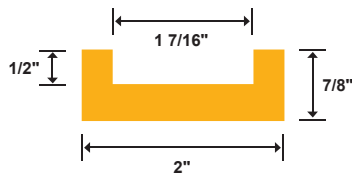

**Redco™ C2060 Channel**  
Part #: R-13858

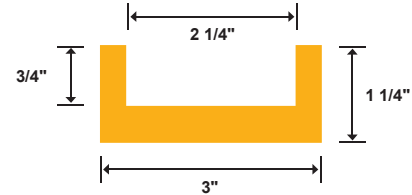

**Redco™ 81X Channel** ●  
Part #: R-5007

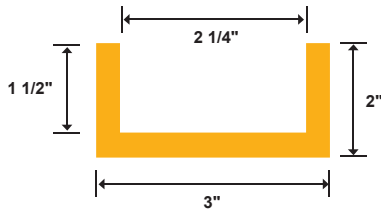

**Redco™ 81X High-Side Channel**  
Part #: R-9087

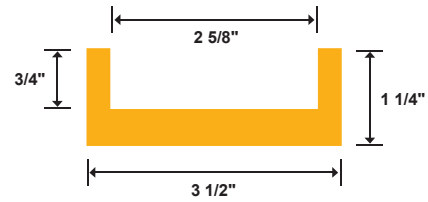

**Redco™ HD-81X Channel** ●  
Part #: R-10576

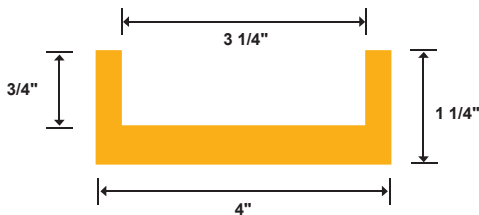

**Redco™ H78 Channel** ●  
Part #: R-10148

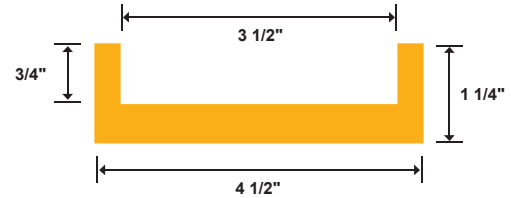

**Redco™ H82 Channel**  
H82, WR78HD, WR82  
Part #: R-4540

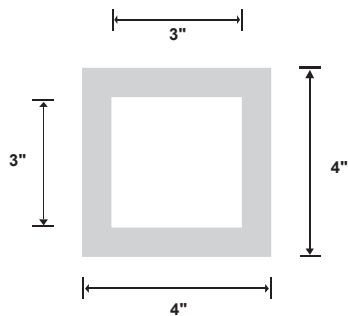

**Redco™ Flyte Profile For Press Over 3x3 Structural Steel**  
Part #: R-4151

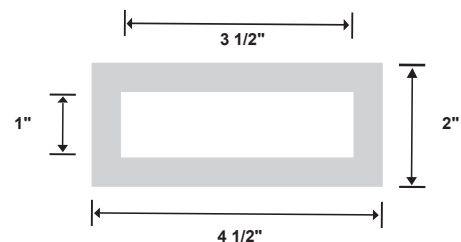

**Redco™ Flyte Profile For Press Over 1 x 3 1/2 Flat Bar**  
Part #: R-4255

● Available in Redco™ Titanium upon request.

**Stocked Length of Channel is 10'**      **Standard Color: Yellow**  
Other colors, custom profiles, and specialty grades for excessive wear or high load applications are available.

# REDCO™ UHMW CHAIN CHANNEL PROFILES

Easy to Install | Lightweight | Custom Sizes Available

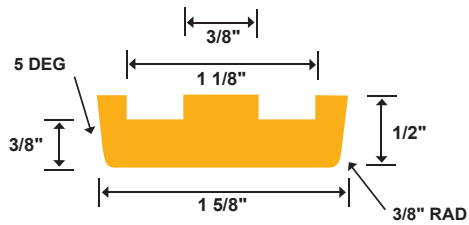

**Redco™ C2060**  
2" Steel Channel Insert  
Part #: R-28853

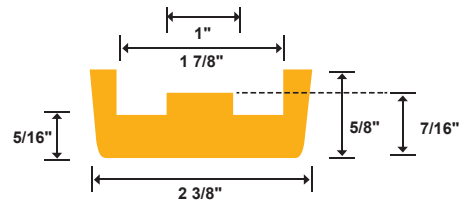

**Redco™ 81X** ●  
3" Steel Channel Insert  
(For 3 x 4.1lb Steel Channel)  
Part #: R-28855

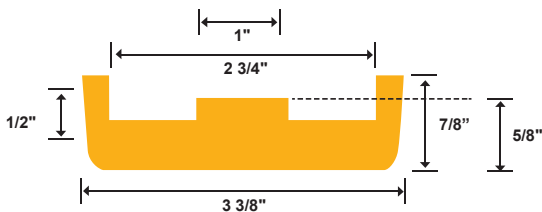

**Redco™ 81XHH** ●  
4" Steel Channel Insert  
(For 4 x 5.4lb Steel Channel)  
Part #: R-28857

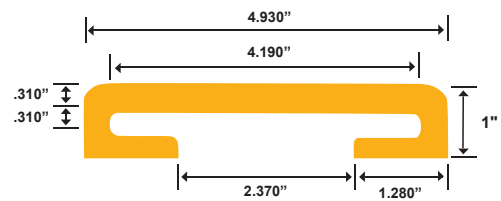

**Redco™ Flange Cap**  
Part #: R-32521

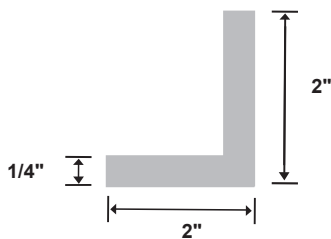

**Redco™ UHMW Angle**  
Part #: UHA-2-.25

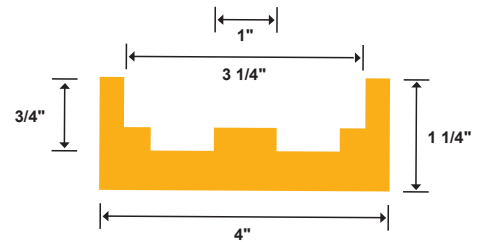

**Redco™ 81XHH/C188/H78**  
E Trak Channel  
Part #: R-10148-E

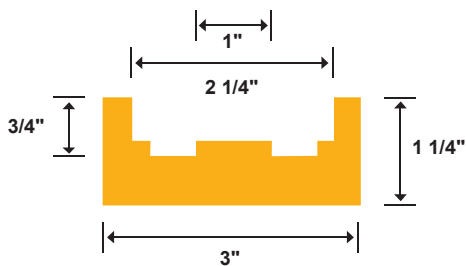

**Redco™ 81X E Trak Channel** ●  
Part #: R-5007-E

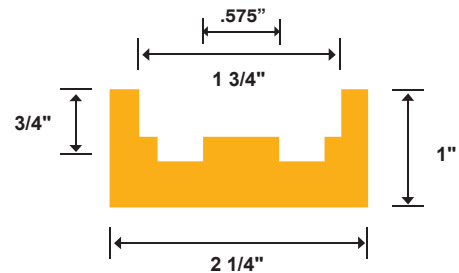

**Redco™ 2080/2080H**  
E Trak Channel  
Part #: R-44004-E

● Available in Redco™ Titanium upon request.

**Stocked Length of Channel is 10'**      **Standard Color: Yellow**  
Other colors, custom profiles, and specialty grades for excessive wear or high load applications are available.