



MINING

PREMIUM SOLUTIONS FOR OPTIMAL LIFE

Redwood Plastics and Rubber has provided solutions for the following:

- Conveyor belts
- Trucks
- Filter Presses
- Bins
- Chutes
- Cranes
- Cylones
- Floatation Cells
- Hoppers
- Steel cables
- Shovels Rigs
- Tracks
- Pipes
- Flanges
- Ladders
- Walkways



Cyclone Urethane Pipes

Similar weight to HDPE with up to ten times the wear life

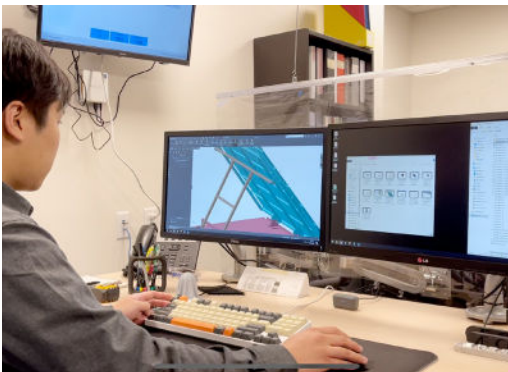

Custom Design

3D design and modelling



Truck Liners

Ideal against gravel, rock, excavation residue



Rubber Lining

Custom fit to solve abrasion and wear issues



sales@redwoodplastics.com

Contact Us for a Quotation.

North America **1.833.381.1195**

Fully equipped with the latest technology, our facilities can manufacture plastic and rubber solutions to almost any specification.

- Rubber Lining
 - Autoclave size 90" Diameter x 42' long
 - Atmosphere Curing of larger sizes available in house
- Cast Urethane
- Rubber Sheet
- Plastic Liners
- CNC Machine Plastics
- Molded Rubber
- Large stock shape inventory
- In-house design and mold making
- Reps for site visits available

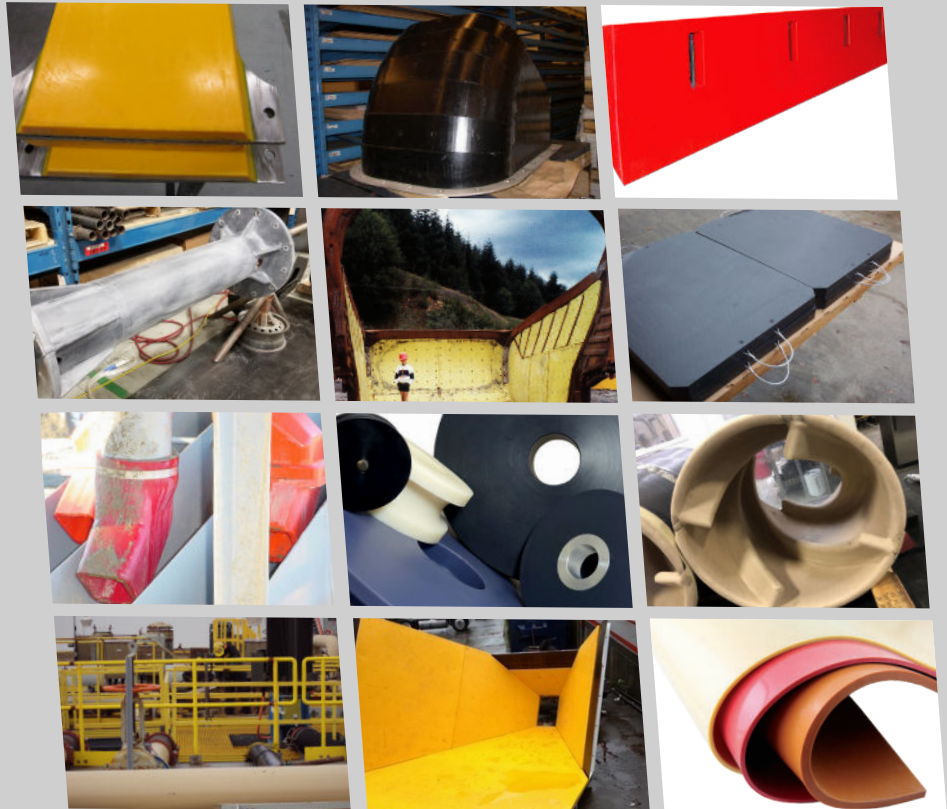

CASE STUDY

Our customer had issues with their Filter Presses when the HDPE Press Plates were wearing out every 2-3 months. Replacing them every few months was draining our customer's budget.

We engineered and installed our own slides made with TuffKast 010. With its high strength and minimal water absorption, our slides proved to last 10 times longer than the original. Our customer is now able to operate their presses with minimal downtime and save costs.

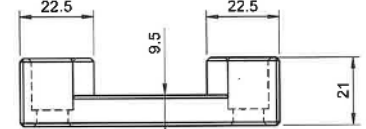

1mm Chamfer On All Edges

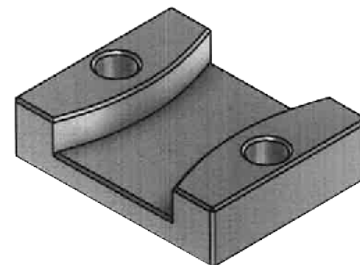
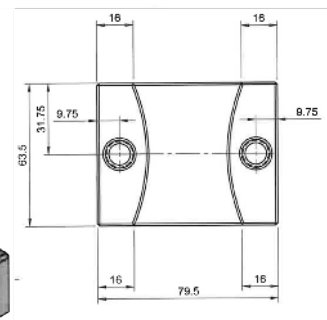

TUFFKAST APPLICATIONS

- ▶ Wear Plates
- ▶ Sheaves
- ▶ Valve Seals
- ▶ Bushings
- ▶ Spacers
- ▶ Forklift Mast Slides